



# FUEL MODULE IN-TANK UNIT REPLACEMENT INSTRUCTIONS

## PRECAUTIONS FOR FUEL SYSTEM SERVICE

TO REDUCE THE RISK OF FIRE AND PERSONAL INJURY IT IS NECESSARY TO OBSERVE THE FOLLOWING PRECAUTIONS:

- Perform this repair ONLY in a properly equipped service facility.
- Position the vehicle in a clear, level, well ventilated work area.
- Make sure there are no sources of spark or combustion near the work area.
- Perform work in a no-smoking area, or post no-smoking signs in the area selected.
- Have readily available a fully functional Class B fire extinguisher of adequate size (such as a 5 pound CO-2 as a minimum.)
- Disconnect the ground cable from the vehicle's battery before performing any operation involving gasoline, gasoline tanks or gasoline lines.
- Allow the vehicle to cool before performing any operation which could possibly expose gasoline or gasoline vapors to hot parts such as catalytic converters, hot light bulbs, or similar components.

- Avoid using extension cords or lights which might overheat or cause sparks.
- Avoid inhaling gasoline fumes and prolonged skin contact with gasoline. Promptly wash any body areas which have been in contact with gasoline.
- Wear approved safety glasses while performing any repairs.
- When raising the vehicles to perform under-vehicle services, use proper hoisting or jacking equipment along with approved safety supports.
- When removing gasoline from a fuel tank use an OSHA approved pump that is specifically designed for handling gasoline. DO NOT USE any other type of pump. Gasoline removed from a fuel tank must be stored in approved gasoline containers.

it is impossible to anticipate all possible risk and conditions under which repairs may be made to a fuel system. Therefore, in addition to the safety concerns listed, you are urged to carefully evaluate the hazards involved in such a service procedure and take whatever further precautions that may be necessary.

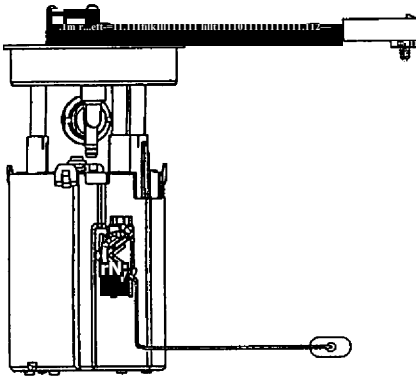

TANK UNIT

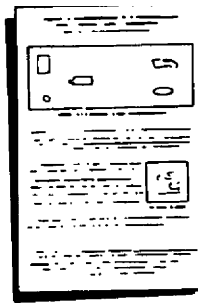

INSTRUCTIONS

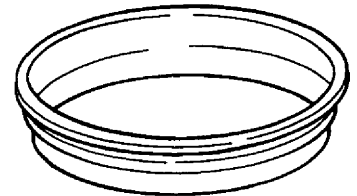

TANK SEAL

**NOTE:** This tank unit may look different than the O.E. unit. This replacement unit meets all specifications established by the O.E. manufacturer. It will fit and function properly if all the installation procedures outlined in this instruction sheet are followed.

**WARNING:** This rotary fuel injection pump WILL NOT work on carbureted fuel systems. It is for electronic fuel injection only.

**CAUTION:** Read these instructions thoroughly from start to finish before attempting to replace the fuel pump.

### MINIMUM TOOL REQUIREMENTS

- Hoist or end lift jack
- OSHA approved safety stands
- OSHA approved fuel transfer pump
- OSHA approved fuel storage containers
- Variety of mechanics hand tools



# FUEL MODULE IN-TANK UNIT REPLACEMENT INSTRUCTIONS

## PRECAUTIONS FOR FUEL SYSTEM SERVICE

### FUEL PUMP REPLACEMENT INSTRUCTIONS

**NOTE:** The words "tank unit" used throughout this instruction sheet means fuel pump tank unit and fuel level sender assembly.

#### I PREPARATIONS

##### A) Relieve fuel system pressure.

**NOTE:** The fuel system can retain gasoline under pressure for a considerable period of time. Opening a pressurized line could spray fuel creating a risk of fire and personal injury.

- 1) Remove the fuel cap from the tank to relieve any tank pressure.
- 2) Locate the Power Distribution Block and remove the Fuel Pump Relay. Relay locations are described inside the cover of the Power Distribution Block.
- 3) With the Fuel Pump Relay removed, crank the engine to bleed down fuel system pressure. The engine will start and stall several times. Continue to momentarily crank the engine several more times. Be sure to turn ignition switch completely to the off position between cycles. Once the engine no longer tries to start, the fuel system pressure is relieved.

**B) Disconnect the negative (-) cable from the battery and position it so it cannot accidentally make contact with the negative (-) battery post during the fuel pump replacement procedure.**

**NOTE:** Be sure an appropriate fire extinguisher is readily accessible before continuing with the service procedure.

**C) Drain the fuel tank with an OSHA approved gasoline transfer pump. Place the suction hose of the pump into the fuel tank through the filler neck.**

**NOTE:** Be sure the hose is completely inserted into the tank. All of the fuel must be drained before trying to remove the fuel tank.

#### II REMOVE AND REPLACE TANK UNIT

- A) Remove the skid plate and any shields that may interfere with removal of the fuel tank.
- B) Remove the fuel filter and vent hoses from the fuel tank.
- C) Support the fuel tank and remove the tank retaining straps (ID). Lower the fuel tank enough to access the tank unit.
- E) Disconnect the fuel lines and electrical wiring to the tank unit. Be sure all other lines and wires are disconnected from the fuel tank before removing the fuel tank from the vehicle.
- F) Carefully lower the fuel tank out of the vehicle.
- G) Remove the tank unit retaining ring by using the appropriate special tool or other appropriate methods. Rotate the ring counterclockwise. Be very careful to not cause sparks during the retaining ring removal procedure as a fire or an explosion could result. **WARNING: HAVE ABSORBENT SHOP TOWELS READILY AVAILABLE WHEN REMOVING THE TANK UNIT. SOME FUEL WILL SPILL WHEN THE TANK UNIT IS REMOVED.**
- H) Clean any debris or foreign material from around the tank unit area of the fuel tank.
- I) Note the orientation of the tank unit locating arrow. Remove the tank unit and tank seal from the fuel tank.
- J) Check the inside of the fuel tank for foreign debris and clean out the tank if necessary.
- K) Place the new tank seal onto the fuel tank. Carefully insert the new tank unit into the fuel tank. Be sure not to bend the level sender float arm when placing the tank unit into the tank.



# FUEL MODULE IN-TANK UNIT REPLACEMENT INSTRUCTIONS

## PRECAUTIONS FOR FUEL SYSTEM SERVICE

L) Align the tank unit locating arrow with its corresponding marks on the tank unit.

M) Install the tank unit retaining ring. Turn the ring clockwise to lock it into place. Torque to manufacturers recommended specifications. Do not over tighten the ring as fuel leaks can occur.

N) Lift the fuel tank into position in the vehicle. Reinstall all fuel lines and electrical connections

**NOTE: it may be necessary to loosen the fuel filter and slide it back in it's mount toward the tank to allow better fit of the fuel line onto the module.**

O) Install the fuel tank retaining straps and tighten the retaining nuts. Do not over tighten the retaining strap nuts.

P) Reinstall the filler neck and vent hoses.

### III WRAP UP

A) Using only equipment designed for use with gasoline, refuel the fuel tank with gasoline. **(NOTE: Be sure to clean up any fuel spills before proceeding.)**

B) With the ignition switch off, reconnect the negative (-) cable to the battery.

C) Reinstall the fuel pump relay in the power distribution center.

D) Start the engine and inspect the fuel lines and connections for leaks. Correct any leaks as necessary.

E) Clear any trouble codes in the electronic control system that may exist as a result of the fuel pump replacement procedure. If necessary, use the specific vehicle service manual for assistance