

E4-WM5-Y177A01

MOUNTING INSTRUCTIONS



Removal:

Place vehicle on a chassis hoist, lift it and remove wheels.



The damper is used as a „rebound strap“, thus the sway bar link must be supported in an appropriate way! Mark position of original spring plate before removal!

Release bottom steering arm/ ABS line/ stabilizer/ brake hose and headlight range adjustment sensor (Xenon).

Remove bottom mount and top mount of support bearing.

Remove complete shock absorber- spring assembly and clamp it in an appropriate strut vice.

Compress suspension spring until tension on support bearing is released.

Release nut and remove original equipment mounting parts.

Installing:

Press original spring plate on to support ring by means of a suitable tool (fig. 4) and fit in marked position on BILSTEIN- shock absorber.

Knock on top cap without tilting (see fig.3).

Reuse original dust cover with bump stop, washer and spring.



Before releasing the spring, care is to be taken to ensure that the ends of the spring rest in the cutouts of the top and bottom rubber pads and.

Replace original mounting parts with new ones if they are not in good condition.

Fit assembled shock absorber-spring assembly to the vehicle in reverse sequence of removal.

All self- locking nuts must be replaced. Tightening torques see list.

List 1

	M8	M 10	M 12	M 14	M 16	Thread
	13	25	45	72	110	Torque Nm
	10	19	34	54	83	Torque ft lb

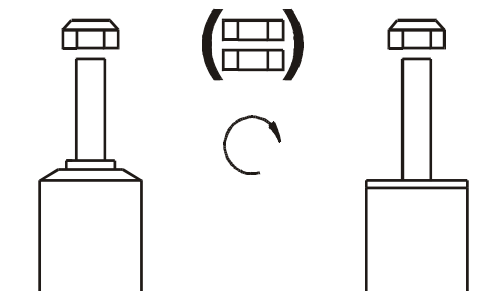

E4-WM5-Y177A01

MOUNTING INSTRUCTIONS



1. Kolbenstangenmutter Anzugsmoment 27 Nm
piston rod nut torque 20 ft lb
2. Stützlager Baugruppe
support bearing assembly
3. Scheibe
washer
4. Federunterlage
spring pad
5. Schraubenfeder
helical spring
6. Schutzrohr
dust cover
7. Federunterlage
spring pad
8. Abschlußkappe *B
top cap *B
9. Federeller
spring plate
10. Stützring *B
support ring *B
11. BILSTEIN- Stoßdämpfer
BILSTEIN- shock absorber
12. Schraube Anzugsmoment 45 Nm
screw torque 34 ft lb
13. Sprengring *B
circlip *B
14. Mutter *B
nut *B

*B - BILSTEIN Lieferumfang
mounting parts delivered by BILSTEIN



Abb./fig.4



Abb./fig.2

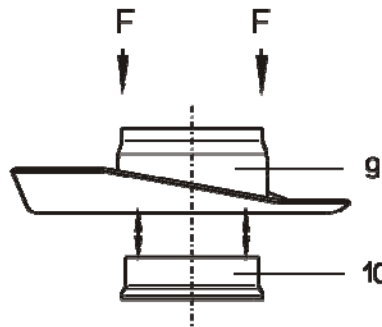
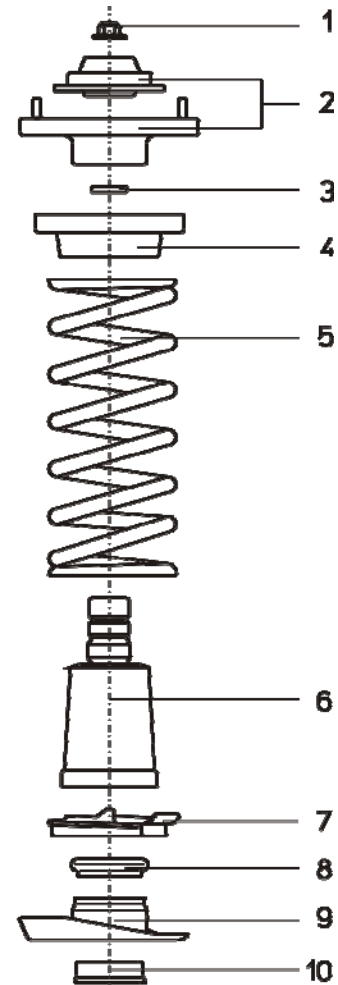

Abb./fig.3

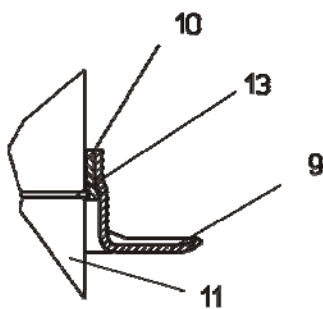

Abb./fig.1

ACHTUNG/ ATTENTION

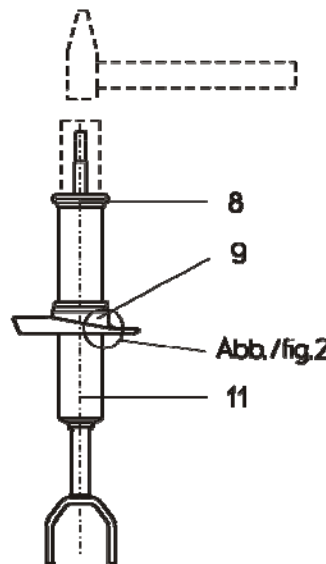
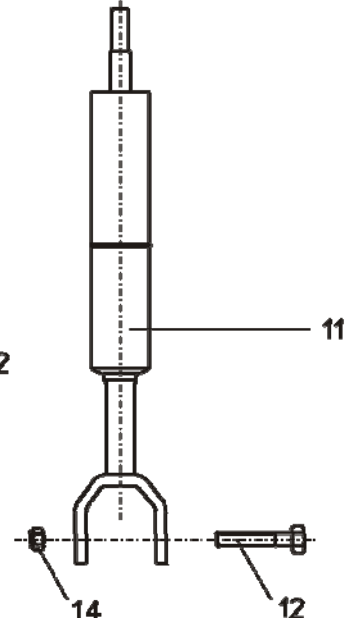
Kolbenstange beim Aufschlagen der
Kappe (8) nicht beschädigen!
Do not damage the piston rod
when knocking on the cap (8)!