

E4-WM5-Y216A00

MOUNTING INSTRUCTION



- list of torques

| | M8 | M 10 | M 12 | M 14 | M 16 | Thread |
|--|----|------|------|------|------|--------------|
| | 13 | 25 | 45 | 72 | 110 | Torque Nm |
| | 10 | 19 | 34 | 54 | 83 | Torque ft lb |

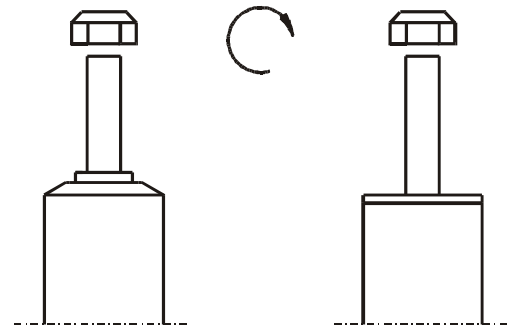

DO NOT USE IMPACT TOOLS FOR LOOSENING OR TIGHTENING FASTENERS, BECAUSE THIS MAY DESTROY THE THREADS. SELF- LOCKING NUTS MUST ONLY BE **USED ONCE!**

All rubber- mounted strut/ damper attachments must not be fully tightened until AFTER the suspension system is loaded (wheels on the ground). Other mounting fasteners (for example brackets) must be securely tightened BEFORE load is placed on the suspension system.

ALL DIAGRAMS ARE GENERALIZED AND NOT TO SCALE! BRACKETS, ETC. SPECIFIC TO STRUT ARE NOT SHOWN!

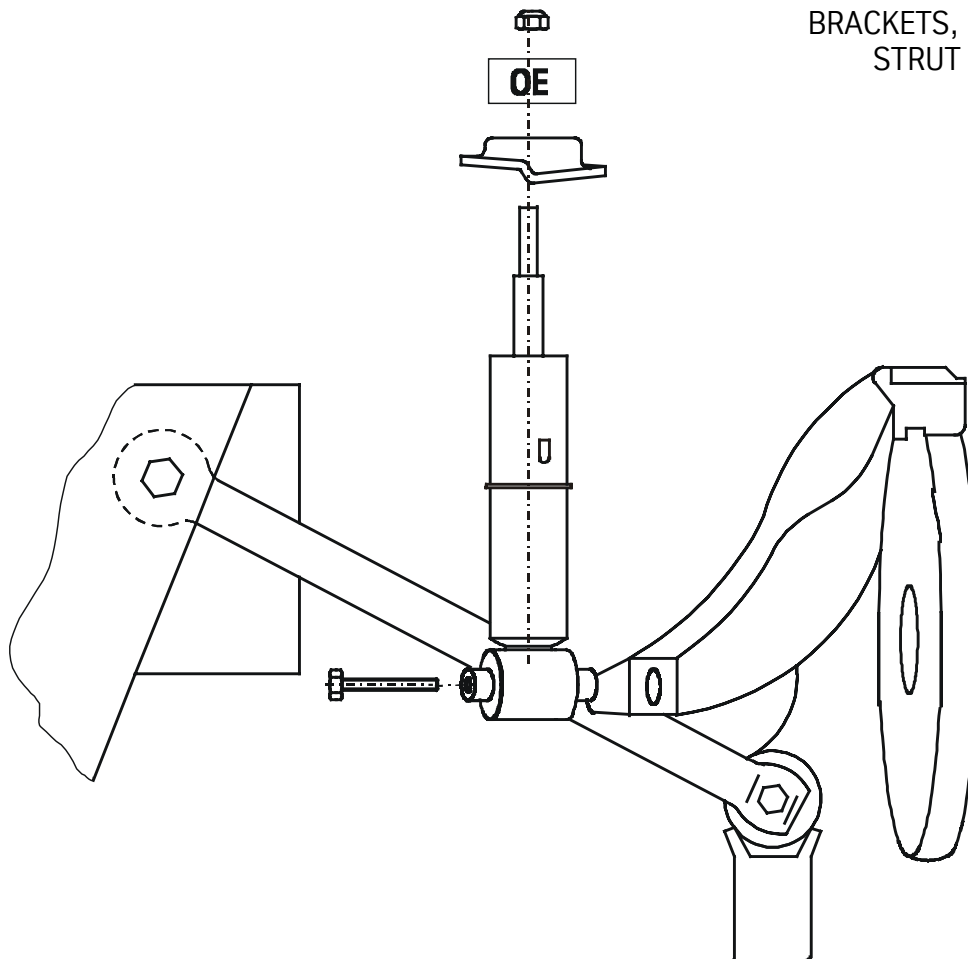

E4-WM5-Y216A00

MOUNTING INSTRUCTION



1. BILSTEIN shock absorber with original spring
2. BILSTEIN shock absorber with BILSTEIN spring
3. Original shock absorber with BILSTEIN spring

Remove

Place vehicle on a chassis hoist, lift it and remove wheels.



The lower control arm must be supported by suitable means!

Remove bottom mount.

If necessary remove stabilizer at suspension arm and rear axle support, also brake hose holder.

At support suspension arm, screw on top, inside must be released a little.

Remove top fixing nuts from support bearing. Do not remove center nut at this time!

Remove complete shock absorber and clamp it in an appropriate strut vise.

Using a suitable spring compressor, compress suspension spring until tension on support bearing is released.

Release center nut and remove original mounting parts and coil spring. Please refer to diagram to identify which parts will be replaced with BILSTEIN-supplied components.

Install

Assemble BILSTEIN and/ or original mounting parts, as well as the new BILSTEIN spring on the BILSTEIN shock absorber in reverse sequence of removal.



Before releasing the spring, care is to be taken to ensure that the spring rest in the cutouts of top and bottom spring plate!

The correct mounting position of the suspension springs can be determined by the printing on the springs; install them with the print upright.

Fit assembled BILSTEIN shock absorber to the vehicle in reverse sequence of removal.