

# E4-WM5-Y297A00

## MOUNTING INSTRUCTION



1. BILSTEIN shock absorber with original spring
  2. BILSTEIN shock absorber with BILSTEIN spring
  3. Original shock absorber with BILSTEIN spring
- ### Removal

Place vehicle on a chassis hoist, lift it and remove wheels.



***The lower control arm must be supported by suitable means!***

Remove bottom mount.

Remove top fixing nuts on left and right side of dome bearing. Remove strut including dome bearing. Release fixing nuts at support bearing. Do not remove center nut at this time!

Remove complete strut and clamp it in an appropriate strut vise.

Using a suitable spring compressor, compress suspension spring until tension on support bearing is released.

Release center nut and remove original mounting parts and coil spring. Please refer to diagram to identify which parts will be replaced with BILSTEIN- supplied components.

### Installation

Fit original/ BILSTEIN mounting parts on strut in reverse sequence to removal, except for dust cover and bump stop, since BILSTEIN- strut has built in bump stop. If there is no dust cover delivered by BILSTEIN, the original one is to be reused.



***Before releasing the spring, care is to be taken to ensure that the spring rest in the cutouts of top and bottom spring plate!***

The correct mounting position of the suspension springs can be determined by the printing on the springs; install them with the print upright.

Fit assembled BILSTEIN strut to the vehicle in reverse sequence of removal.

All rubber- mounted strut/ damper attachments must not be fully tightened until AFTER the suspension system is loaded ( wheels on the ground). Other mounting fasteners ( for example brackets) must be securely tightened BEFORE load is placed on the suspension system.

**DO NOT USE IMPACT TOOLS FOR LOOSENING OR TIGHTENING FASTENERS, BECAUSE THIS MAY DESTROY THE THREADS. SELF- LOCKING NUTS MUST ONLY BE USED ONCE!**

# E4-WM5-Y297A00

## MOUNTING INSTRUCTION



### - list of torques

	M8	M 10	M 12	M 14	M 16	Thread
	13	25	45	72	110	Torque Nm
	10	19	34	54	83	Torque ft lb

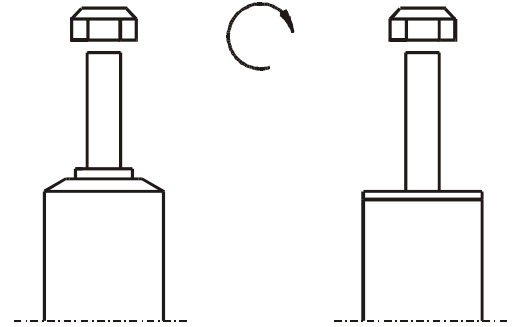

ALL DIAGRAMS ARE  
GENERALIZED  
AND NOT TO SCALE!  
BRACKETS, ETC. SPECIFIC  
TO STRUT ARE NOT SHOWN!

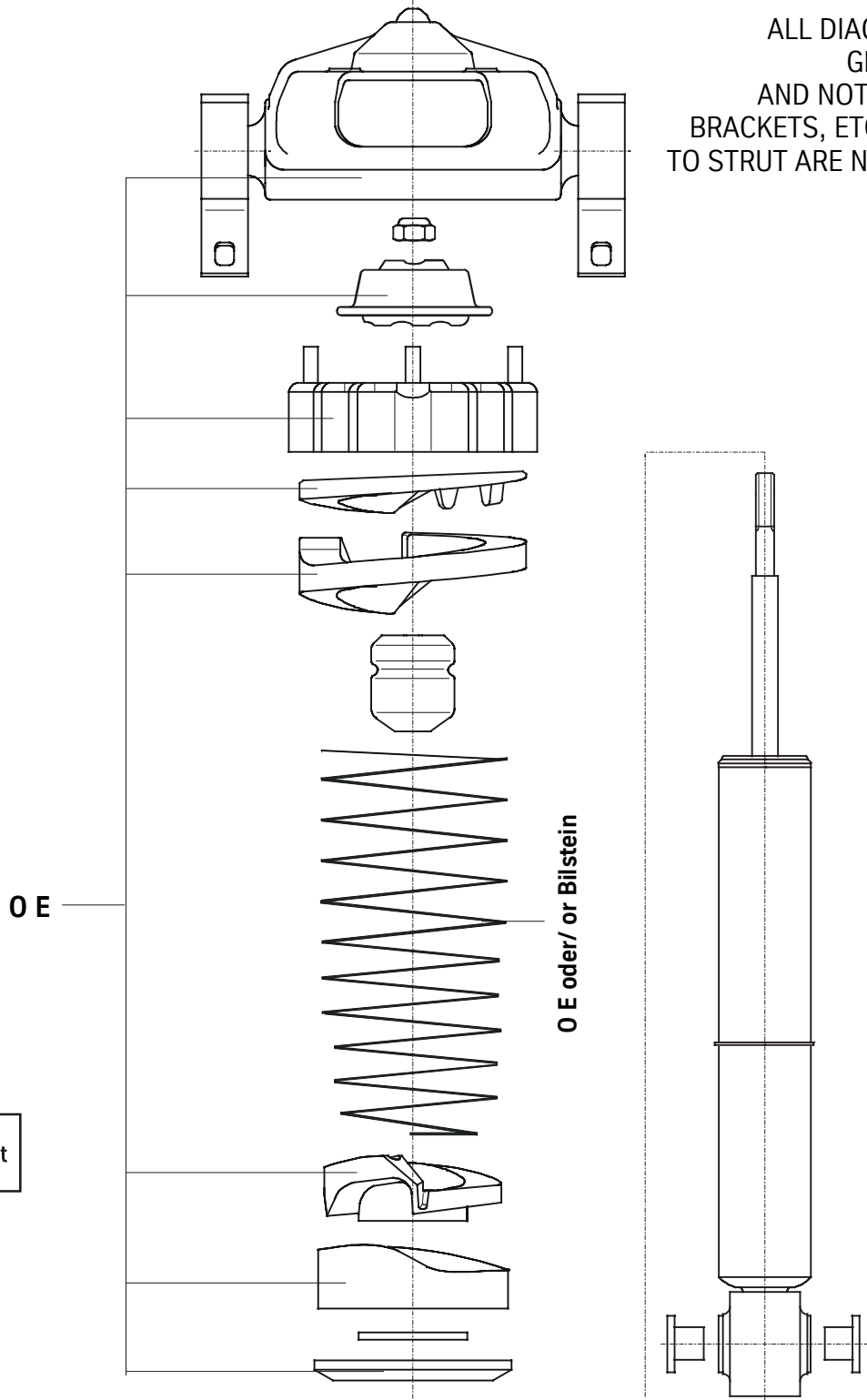

**OE** = Original Equipment