

# E4-WM5-Y217A00

## MOUNTING INSTRUCTION



### After installation please observe the following points:

### Before installation please observe the following points:

- After installing the suspension system, caster and camber must be checked and adjusted according to manufacturer's specifications.
  - Check and reset load- dependent brake compensator and ABS system according to manufacturer's specifications.
  - Check and adjust headlight aim.
- Because the vehicle has been lowered, freedom of movement for all wheel- / tire- combinations must be checked.
- All rubber- mounted strut/ damper attachments must not be fully tightened until AFTER the suspension system is loaded (wheels on the ground). Other mounting fasteners (for example brackets) must be securely tightened BEFORE load is placed on the suspension system.
- Connect the negative battery pole.

- Read all information in this manual carefully.
  - All suspension components are fitted and removed acc. to the manufacturer's specifications for fitting and removing, if not otherwise required in these instructions.
- Check the product for all components before starting installation!
- Check that dimensions and fastening points are comparable between the original and Bilstein shock absorbers.
- Remove the negative battery pole.
- Directional references (left, right, front, rear) are always with reference to the driving direction.
- The tested vehicles are left- hand drive vehicles.

All diagrams are generalized  
and not to scale!  
Brackets, etc. specific to  
strut are not shown!

# E4-WM5-Y217A00

## MOUNTING INSTRUCTION



**A**

### STANDARD SHOCK-ABSORBER

( SA\*, AA\*, SS\*, SX\*, SG\* )

1. BILSTEIN shock absorber with original spring
2. BILSTEIN shock absorber with BILSTEIN spring
3. Original shock absorber with BILSTEIN spring

#### Installation

Assemble BILSTEIN and/ or original mounting parts on BILSTEIN shock absorber in reverse order as removal.

Fit assembled shock absorber to the vehicle in reverse order as removal. For to guarantee correct fitting of mounting parts, it is necessary to compare the Type- No, printed on damper- label with the charts on the following pages.

All self- locking nuts must be replaced.  
Tightening torques see list below.



#### Remove

Place vehicle on a wheel-free car hoist, lift it and remove wheels.

***The lower control arm must be supported by suitable means!***

Remove bottom mount.

Remove top fixing mount.

Remove shock absorber from vehicle.

Remove original mounting parts.

# E4-WM5-Y217A00

## MOUNTING INSTRUCTION



### **B** SPRING CARRIED SHOCK ABSORBER

( FSA\*, FAA\*, FSS\*, FSX\*, FSG\* )

1. BILSTEIN shock absorber with original spring
2. BILSTEIN shock absorber with BILSTEIN spring
3. Original shock absorber with BILSTEIN spring

#### Installation

Assemble BILSTEIN and/ or original mounting parts, as well as the new BILSTEIN spring on the shock absorber in reverse order as removal.



***Before releasing the spring, care is to be taken to ensure that the ends of the spring rest in the cut outs of the top and bottom spring plates.***

The correct mounting position of the suspension springs can be determined by the printing on the springs; install them with the print upright.

Fit assembled shock absorber to the vehicle in reverse order as removal. For to guarantee correct fitting of mounting parts, it is necessary to compare the Type- No, printed on damper-label with the charts on the following pages.

#### Remove

Place vehicle on a wheel-free car hoist, lift it and remove wheels.



***The lower control arm must be supported by suitable means!***

Remove bottom mount.

Remove top fixing nuts from support bearing.  
**Do not remove centre nut at this time!**

Remove complete shock absorber and clamp it in an appropriate strut vice.

Compress suspension spring until tension on support bearing is free to move.

Release centre nut and remove original mounting parts and coil spring. Please check, which original mounting parts will be renewed with mounting parts supplied by BILSTEIN.

# E4-WM5-Y217A00

## MOUNTING INSTRUCTION



### list of torques

	M 8	M 10	M 12	M 14	M 16	Thread
	13	25	45	72	110	Torque Nm
	10	19	34	54	83	Torque ft lb

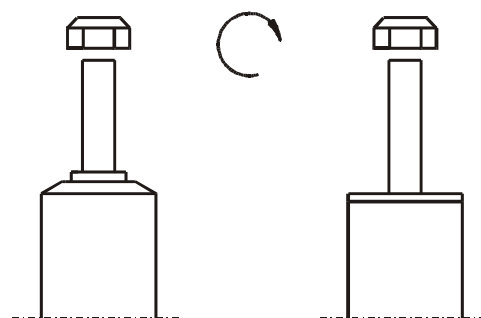

**Do not use an impact tool to loosen or tighten fasteners due to possible damage to the product. Self- locking nuts must only be used once!**

All rubber- mounted strut/ damper attachments must not be fully tightened until AFTER the suspension system is loaded (wheels on the ground). Other mounting fasteners (for example brackets) must be securely tightened BEFORE load is placed on the suspension system.

# E4-WM5-Y217A00

## MOUNTING INSTRUCTION



ALL DRAWINGS ARE GENERALIZED!  
BRACKETS, ETC. SPECIFIC TO  
STRUT ARE NOT SHOWN!

### TYPES OF SHOCK ABSORBER

\* siehe Typenliste S. 1/ see application guide side 1

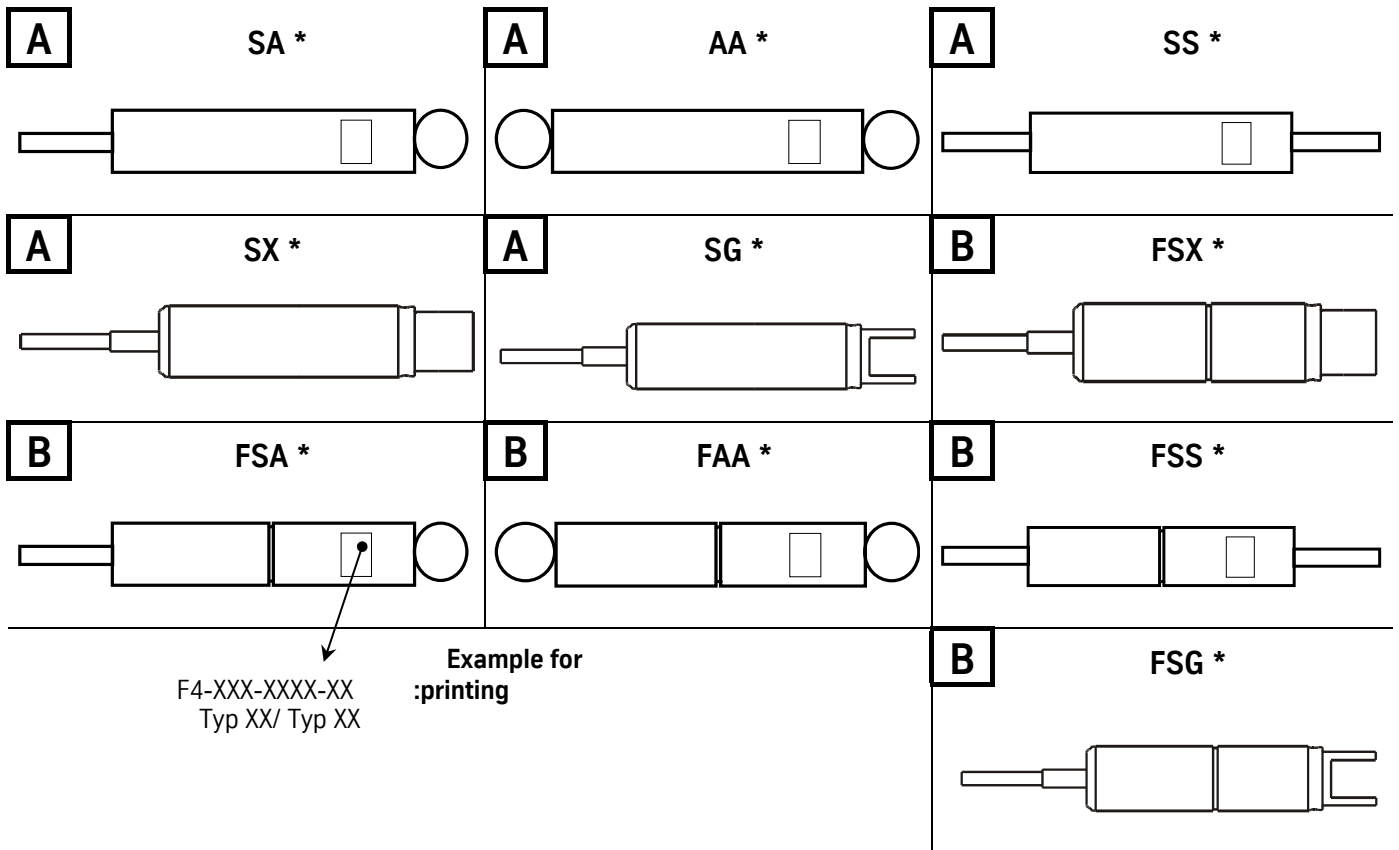

If no dust cover is delivered by BILSTEIN, original dust cover must be reused or replaced.

Do not damage the piston rod when knocking a top cap ( 6 )!

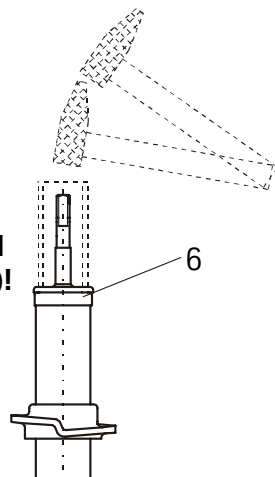

When fitting the spring plate ( 1 ) care must be taken to ensure that the circlip ring ( 2 ) is seated correctly!

X = Fitting of plates with chamfer (if exist)

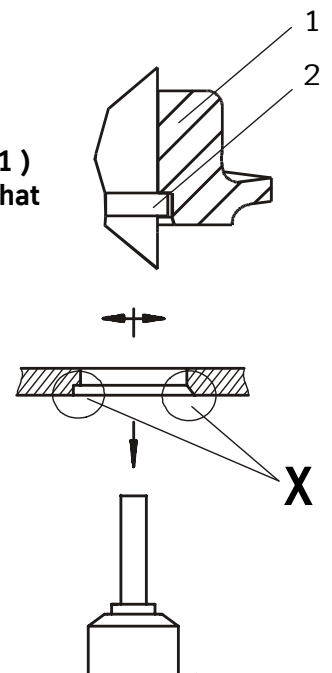

# E4-WM5-Y217A00

## MOUNTING INSTRUCTION



<p><b>Typ1</b></p> <h1>OE</h1> <p>- Original Equipment Original mounting parts</p>	<p><b>Typ2</b></p>	<p><b>Typ3</b></p>	<p><b>Typ4</b></p>	<p><b>Typ5</b></p>
<p><b>Typ6</b></p>	<p><b>Typ7</b></p>	<p><b>Typ8</b></p>	<p><b>Typ9</b></p>	<p><b>Typ10</b></p>
<p><b>Typ11</b></p>	<p><b>Typ12</b></p>	<p><b>Typ13</b></p>	<p><b>Typ14</b></p>	<p><b>Typ15</b></p>
<p><b>Typ16</b></p>	<p><b>Typ17</b></p>	<p><b>Typ18</b></p>	<p><b>Typ19</b></p>	<p><b>Typ20</b></p>
<p><b>Typ21</b></p>	<p><b>Typ23</b></p>	<p><b>Typ24</b></p>	<p><b>Typ25</b></p>	
<p><b>Typ22</b></p>				

# E4-WM5-Y217A00

## MOUNTING INSTRUCTION



<p><b>Typ26</b></p>	<p><b>Typ27</b></p>	<p><b>Typ28</b></p>	<p><b>Typ29</b></p>	<p><b>Typ30</b></p>
<p><b>Typ31</b></p>	<p><b>Typ32</b></p>	<p><b>Typ33</b></p>	<p><b>Typ34</b></p> <p>Slotted nut torque to min. 48 Nm (35 lb/ft) and insert cotter pin</p> <p>Damper body</p> <p>Vehicle</p>	
<p><b>Typ36</b></p>	<p><b>Typ37</b></p>	<p><b>Typ38</b></p>	<p><b>Typ39</b></p>	<p><b>Typ40</b></p>
<p><b>Typ41</b></p>	<p><b>Typ42</b></p>	<p><b>Typ43</b></p>	<p><b>Typ44</b></p>	