

E4-WM5-Y226A01

MOUNTING INSTRUCTION



SPRING CARRIED SHOCK ABSORBER

(FSA*, FAA*, FSS*, FSX*, FSG*)

1. BILSTEIN shock absorber with original spring
2. BILSTEIN shock absorber with BILSTEIN spring
3. Original shock absorber with BILSTEIN spring

Remove

Place vehicle on a chassis hoist, lift it and remove wheels.



The lower control arm must be supported by suitable means!

Remove bottom mount.

Remove top fixing nuts from support bearing. Do not remove centre nut at this time!

Remove complete shock absorber and clamp it in an appropriate strut vice.

Compress suspension spring until tension on support bearing is released.

Release centre nut and remove original mounting parts and coil spring. Please check, which original mounting parts will be renewed with mounting parts supplied by BILSTEIN.

Install

Assemble BILSTEIN and/ or original mounting parts, as well as the new BILSTEIN spring on the shock absorber in reverse sequence of removal.



Before releasing the spring, care is to be taken to ensure that the ends of the spring rest in the cut outs of the top and bottom spring plates.

The correct mounting position of the suspension springs can be determined by the printing on the springs; install them with the print upright.

Fit assembled shock absorber to the vehicle in reverse sequence of removal. For to guarantee correct fitting of mounting parts, it is necessary to compare the Type- No, printed on damper-label with the charts on the following pages.

E4-WM5-Y226A01

MOUNTING INSTRUCTION



B

STANDARD SHOCK-ABSORBER

(SA*, AA*, SS*, SX*, SG*)

1. BILSTEIN shock absorber with original spring
2. BILSTEIN shock absorber with BILSTEIN spring
3. Original shock absorber with BILSTEIN spring

Remove

Place vehicle on a chassis hoist, lift it and remove wheels.



The lower control arm must be supported by suitable means!

Remove bottom mount.

Remove top fixing mount.

Remove shock absorber from vehicle.

Remove original mounting parts.

Install

Assemble BILSTEIN and/ or original mounting parts on BILSTEIN shock absorber in reverse sequence of removal.

Fit assembled shock absorber to the vehicle in reverse sequence of removal. For to guarantee correct fitting of mounting parts, it is necessary to compare the Type- No, printed on damper- label with the charts on the following pages.

All self- locking nuts must be replaced. Tightening torques see list below.

list of torques						
	M8	M 10	M 12	M 14	M 16	Thread
	13	25	45	72	110	Torque Nm
	10	19	34	54	83	Torque ft lb

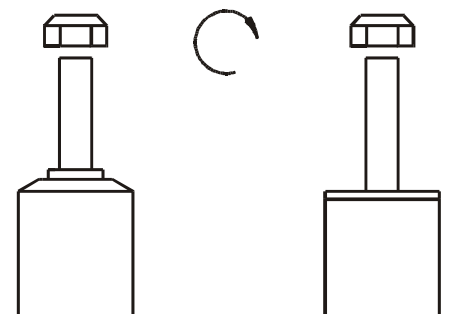

Do not use an impact tool to loosen or tighten fasteners due to possible damage to the product.

Self- locking nuts must only be used once!

All rubber- mounted strut/ damper attachments must not be fully tightened until AFTER the suspension system is loaded (wheels on the ground). Other mounting fasteners (for example brackets) must be securely tightened BEFORE load is placed on the suspension system.

E4-WM5-Y226A01

MOUNTING INSTRUCTION



ALLE DARSTELLUNGEN SIND SCHEMATISCH!

ALL DRAWINGS ARE GENERALIZED!
BRACKETS, ETC. SPECIFIC TO
STRUT ARE NOT SHOWN!

TYPES OF SHOCK ABSORBER

* see application guide side M54

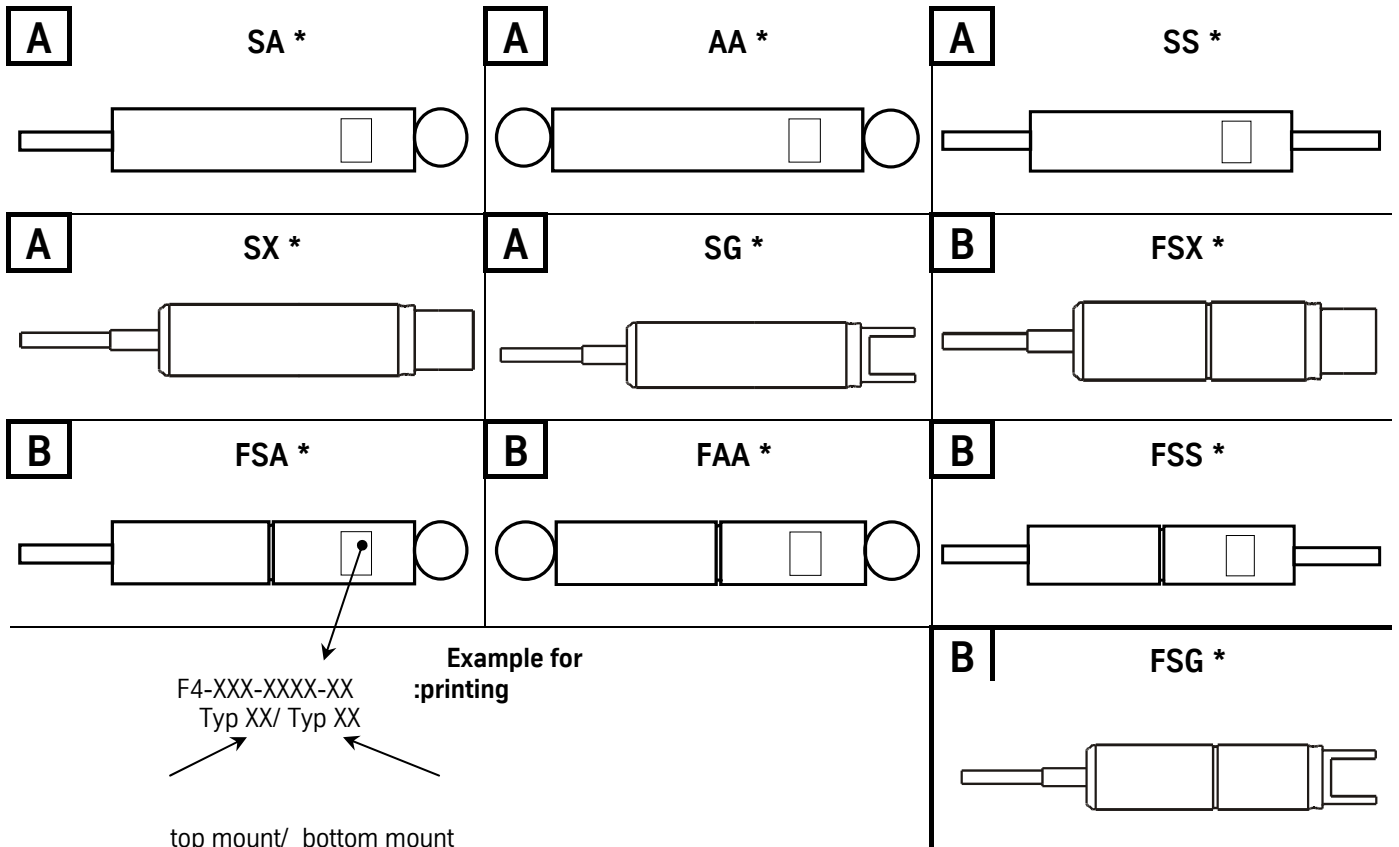

If no dust cover is delivered by BILSTEIN, original dust cover must be reused or replaced.

Do not damage the piston rod when knocking a top cap (6)!

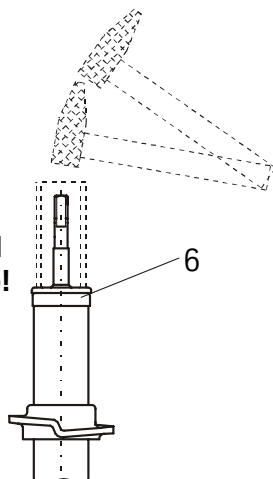

When fitting the spring plate (1) care must be taken to ensure that the circlip ring (2) is seated correctly!

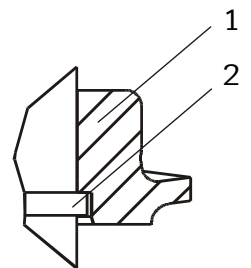

X = Fitting of plates with chamfer (if exist)

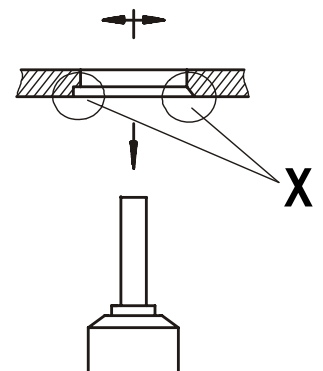

E4-WM5-Y226A01

MOUNTING INSTRUCTION



<p>Typ1</p>	<p>Typ2</p>	<p>Typ3</p>	<p>Typ4</p>	<p>Typ5</p>
<p>Typ6</p>	<p>Typ7</p>	<p>Typ8</p>	<p>Typ9</p>	<p>Typ9</p> <p>oben/top M10x1</p> <p>OE</p>
<p>Typ11</p>	<p>Typ12</p>	<p>Typ13</p>	<p>Typ14</p>	<p>Typ15</p>
<p>Typ16</p>	<p>Typ17</p>	<p>Typ18</p>	<p>Typ19</p>	<p>Typ20</p>
<p>Typ21</p>	<p>Typ22</p>	<p>Typ23</p>	<p>Typ24</p>	<p>OE = Original Anbauteile Original Equipment</p>