



**VW Golf IV sedan**  
**VW Bora sedan**  
**VW New Beetle**  
**VW New Beetle Cabrio**  
**AUDI A3**  
**SEAT Toledo**  
**SEAT Leon**



**Before installation please observe  
the following points:**

- Read all information in this manual carefully.  
All suspension components are fitted and removed acc. to the manufacturer's specifications for fitting and removing, if not otherwise required in these instructions.
- Check that your vehicle type is listed in the certificate as being released for this kit.
- Check the product for all components before starting installation!
- Check that dimensions and fastening points are comparable between the original and Bilstein shock absorbers.
- Remove the negative battery pole.
- Directional references (left, right, front, rear) are always with reference to the driving direction.
- The test vehicles are left- hand drive cars.

**After installation please observe  
the following points:**

- Set the vehicle height by adjusting spring plates and lock nuts on the new dampers. Only use the supplied spanner wrenches.
- After installing the suspension system, caster and camber must be checked and adjusted according to manufacturer's specifications.  
Check and reset load- dependent brake compensator and ABS system according to manufacturer's specifications.
- Check and adjust headlight aim.
- Because the vehicle has been lowered, freedom of movement for all wheel-/ tire- combinations must be checked.
- All rubber- mounted strut/ damper attachments must not be fully tightened until AFTER the suspension system is loaded (wheels on the ground). Other mounting fasteners (for example brackets) must be securely tight-ened BEFORE load is placed on the suspension system.
- Connect the negative battery pole.
- All diagrams are generalized and not to scale!  
brackets, etc. specific to strut are not shown!



- list of torques

	M8	M 10	M 12	M 14	M 16	Thread
	13	25	45	72	110	Torque Nm
	10	19	34	54	83	Torque ft lb

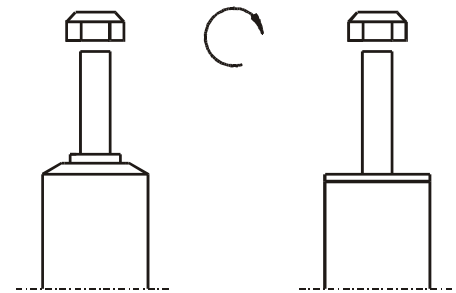

**Do not use an impact tool to loosen or tighten fasteners due to possible damage to the product.**  
**Self- locking nuts must only be used once!**



## mounting instruction for front axle

### Remove

Place vehicle on a chassis hoist, lift it and remove wheels.

Vehicles equipped **with xenon headlight** the sensor for the headlamp levelling controller must be removed before.



***The lower control arm must be supported by suitable means!***

Remove bottom mount.

Remove top fixing nut from support bearing. Do not remove center nut at this time!

Remove complete strut and clamp it in an appropriate strut vise.

Using a suitable spring compressor, compress suspension spring until tension on support bearing is released.

Release center nut and remove original mounting parts and coil spring. Please refer to diagram to identify which parts will be replaced with BILSTEIN-supplied components.

### Install

Assemble BILSTEIN and/ or original mounting parts, as well as the new BILSTEIN spring on the BILSTEIN strut in reverse sequence of removal.



***IMPORTANT! Spring plates must not be adjusted outside the ranges specified below!***

The correct mounting position of the suspension springs can be determined by the printing on the springs; install them with the print upright.

Do not reuse original-bumper, since BILSTEIN-strut has built in bump stop.

Fit assembled BILSTEIN strut to the vehicle in reverse sequence to removal.

The adjustment range of the spring plates is only approved within the range of the values given in Point I. Adjustment must be carried out so that the body is level when the vehicle is empty apart from the driver. The lowest approved adjustment and the permissible adjustment range are to be entered, stating the fixed axle reference points. (Example, see below).

<b>Manufacturer</b>	<b>Volkswagen, VW</b>		
<b>ABE-/ EG- BE- No.</b>	e1*96/79*0071*.. e1*98/14*0071*.. e1*2001/116*0071*..	e1*97/27*0106*.. e1*98/14*0106*.. e1*2001/116*0106*..	e1*2001/116*0205
<b>type designation</b>	1J	9C	1Y
<b>model</b>	Golf 4 sedan, Bora sedan	New Beetle	New Beetle Cabrio

<b>Manufacturer</b>	<b>AUDI</b>	<b>Seat</b>
<b>ABE-/ EG- BE- No.</b>	e1*95/54*0042*.. e1*98/14*0042*..	e9*97/27*0026*.. e9*98/14*0026*..
<b>type designation</b>	8L	1M
<b>model</b>	AUDI A3 (<20003)	Toledo, Leon

I.

<b>FRONT</b>		
<b>spring part number</b>	main spring <b>E4-FD1-Y017B00</b>	
<b>shock absorber part number</b>	Strut clamping seat- ø: 55 mm <b>VE3-C429</b>	
<b>permissible adjustment range</b>	max. perm. axle load up to <b>1020 kg ( 2244 lb)</b> 195 – 215 mm* = 20 mm range	max. perm. axle load up to <b>1060 kg ( 2332 lb)</b> 200 – 215 mm* = 15 mm range
<b>* measurement:</b>	top edge of spring seat down to the center of bottom mounting screw	

<b>REAR</b>	<b>maximum permissible axle load 960 kg ( 2112 lb)</b>
<b>spring part number</b>	main spring <b>E4-FD1-Y373A00</b>
<b>shock absorber part number</b>	<b>BE3-C653</b>
<b>permissible adjustment range</b>	<b>55 – 75 mm* = 20 mm range</b>
<b>* measurement:</b>	top edge of spring seat down to original spring seat

- There are no technical objections against the use of all O.E. wheel-/ tyre combinations except for **205/55 R16 on 7,0 x16 ET 42**. With this combination spacers of 5 mm thickness which a special certificate have to be installed on axle 1.
- Because of the increased bump travel on axle **1 and 2**, all special wheel-/ tyre combinations which have already been entered (approved) must be re-examined with regard to freedom of motion. Critical areas are f.e. area of inner and outer tyre flank above centre of wheel. In so far as these wheel-/ tyre combinations are not listed below, the examination must be carried out by an officially recognised expert or test engineer at a TÜV/TÜH test facility. The vehicle registration document in accordance with §21 German Road Traffic Licensing Code - StVZO must be presented. Any certificates already obtained with regard to special wheel-/ tyre combinations are invalid if they do not contain a reference to the suspension system described in this document.
- The specified minimum height of the coupling ball above the road surface with the permissible total weight of the vehicle (acc. DIN 74058) is 350 mm.
- The dynamic ground clearance is decreased by the provision of special springs/dampers which increase the bump travel of the front and rear axle. In the case of the test vehicle, the distance from the ground amounted to **80 mm** under the motor crossbar. Care must be taken when driving over humps, barriers and heightened paving or road surfaces. If special spoilers, aprons and exhaust systems are mounted, attention must be paid to the decreased overhang angle (driving up ramps etc.).

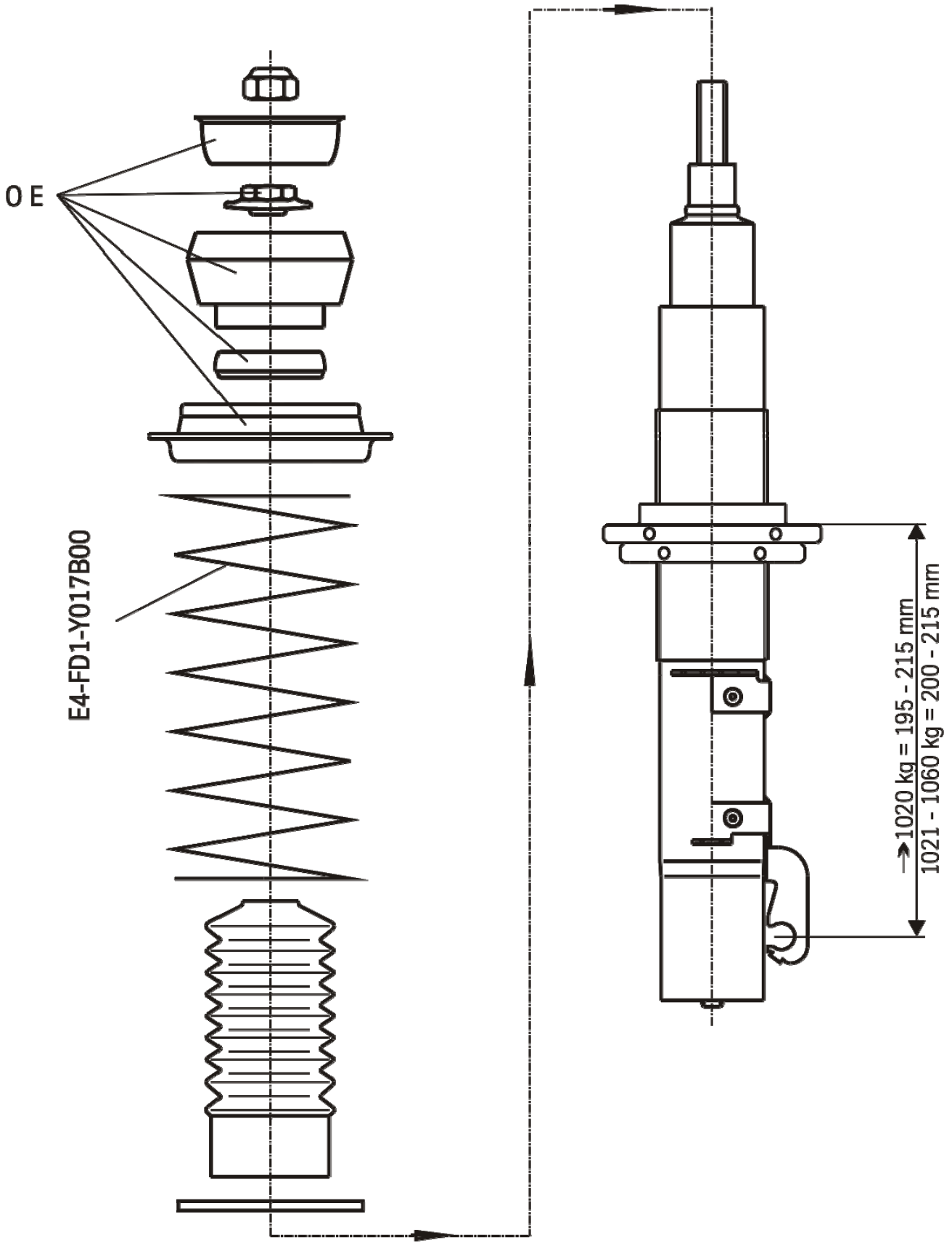

**OE** = Original Anbauteile

## Remove

Place vehicle on a chassis hoist, lift it and remove wheels.



***The lower control arm must be supported by suitable means!***

Remove top and bottom fixing mount from support bearing.

Remove shock absorber and original mounting parts.

## Install

Fit BILSTEIN and/ or original mounting parts in BILSTEIN shock absorber in reverse sequence of removal.

Fit BILSTEIN shock absorber to the vehicle in reverse sequence of removal.

The correct mounting position of the suspension springs can be determined by the printing on the springs; install them with the print upside down.

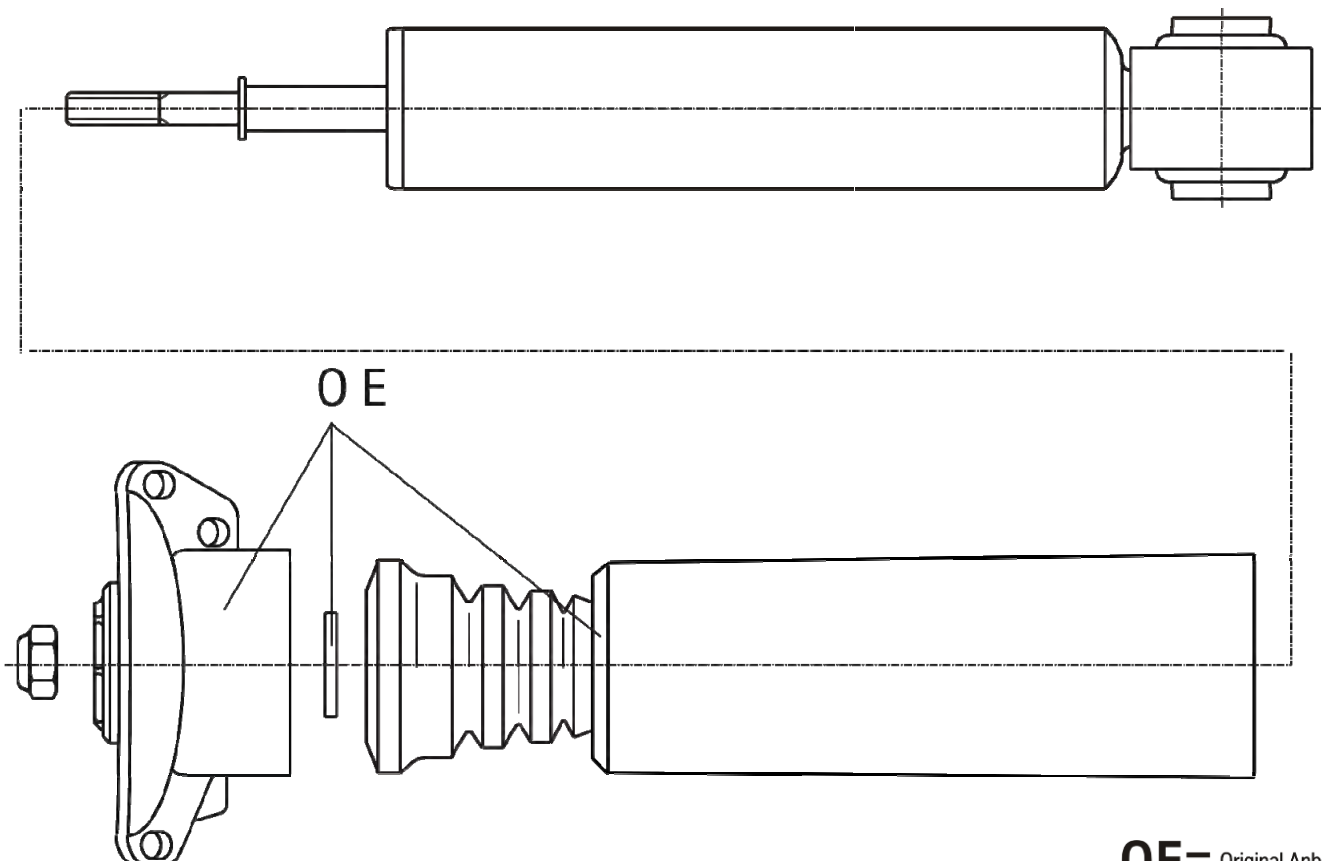

**OE** = Original Anbauteile

- mounting instuction for rear axle height adjustment

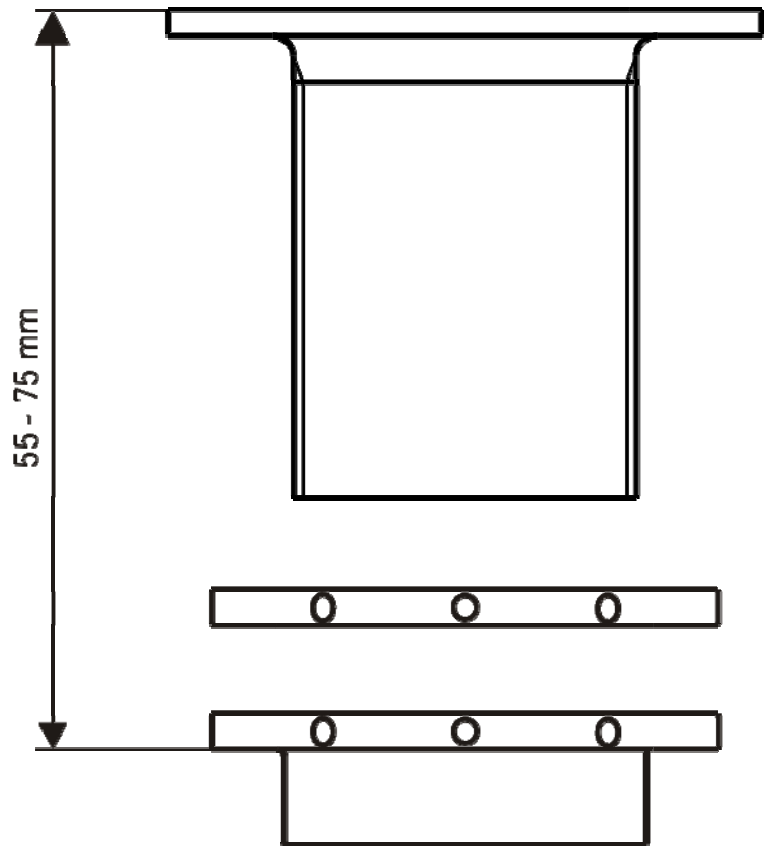

**ACHTUNG/ATTENTION**

Aufdruck ist entgegengesetzt  
der Einbaulage/  
printing is upside down

**E4-FD1-Y373A00**

