



## HOW TO INSTALL YOUR NEW FUEL PUMP

Handle your new pump with care. Make sure no dirt enters the inlet and outlet ports. Be sure to remove any and all protective plugs. Make sure all fittings and hoses are in good condition and properly installed and secure. Check for fuel and oil leaks with engine at idle speed only. FOR YOUR PROTECTION THE HOOD SHOULD BE CLOSED WHEN REVVING THE ENGINE.

### Installation Instructions:

---

Follow This Sequence:

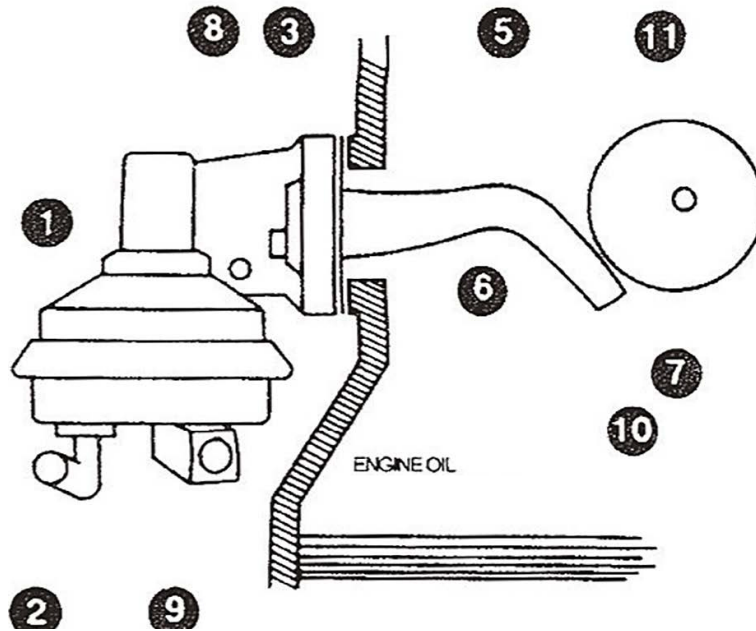

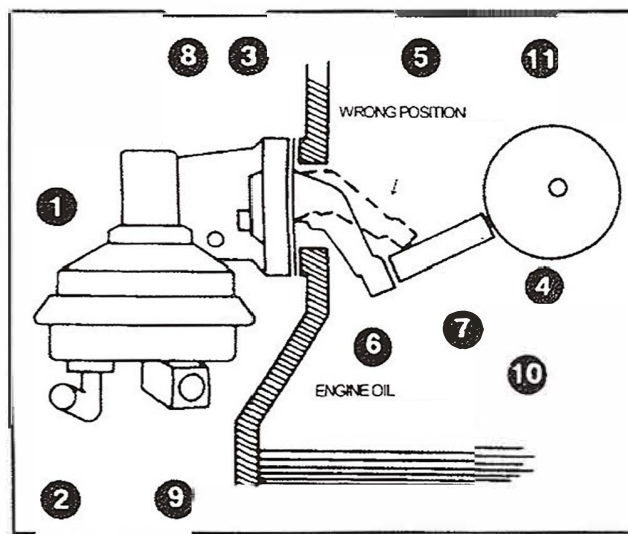

1. Before removing old fuel pump, note whether fuel section is in “up” or “down” position.
2. Disconnect fuel lines from pump. Check to see if swelling or cracks are evident in the lines.
3. Remove the mounting bolts and pump from the engine block. Then remove the old mounting gasket from the block and clean the surface.
4. Check the push rod (if used) for signs of wear. Replace if necessary.
5. Add grease to the rocker arm pad and rocker arm cavity to lubricate the internal parts.
6. Place the new mounting gasket onto the surface of the pump, holding it in place while starting bolts thru pump flange and gasket.
7. After the bolts are started into engine block, tilt the pump either toward or away from the block. This correctly places the lever against the cam.  
 NOTE: On push rod driven pumps, make sure the pump lever is mounted under the push rod; if not, damage usually results. A common practice is to use a hacksaw blade or similar object to hold the push rod up while placing the pump lever underneath the push rod when the engine is at low cam. If the pump is properly positioned, you should hear an internal squawking noise with each movement of the pump.

8. Tighten both mounting bolts evenly from one side to the other firmly.
  
9. Align and tighten both fuel lines, then check for leakage. Make sure all fittings, hoses and clamps are securely tightened to prevent leakage that could cause fire when starting engine.
  
10. **CAUTION:** If the old pump had a ruptured diaphragm gasoline may have leaked into the crankcase. Check and change engine oil if necessary to prevent engine bearing damage due to poor lubrication.
  
11. If after following the above instructions step-by-step the pump does not deliver sufficient fuel there is a strong possibility of engine cam wear. This should be checked.

**NOTE:** This fuel pump is not approved for aircraft or marine use. This product intended only for use as originally specified by the OEM manufacturer and/or the catalog.